

## MARS 1500 X2 Package: Pricing and Specifications

The MARS 1500 package comes with everything you need to manage a 1 acre pond; including the aeration diffuser, a 1/3 hp compressor, weatherproof compressor enclosure, 100 feet of self-weighted hosing and 1 years worth of Triplepoint Blend Pond Pro-biotic. All of this is provided for an F.O.B. price of \$3,623.00.

### I. Two MARS 1500 Diffuser Units

#### Optimized Pond Treatment

- Patented synergistic venturi effect mixes and oxygenates the entire water column.
- Eight micro-bubble diffusers provide peak oxygen transfer.
- Large bubble diffuser for maximum mixing.
- Proprietary air regulation system.

#### Low Maintenance Design

- Constructed with heavy-duty polyvinyl material
- Utilizes self-cleaning technology so your MARS maintains maximum efficiency.
- All diffusers are positioned high above pond muck, minimizing the potential for fouling.
- All orifices feature positive backflow sealing keeping water from entering your system.

#### Simple to Install

- Negative-buoyancy frame keeps the unit submerged.
- Wide platform securely holds the unit level in place.
- Stainless steel recovery loop allows for easy placement and retrieval.

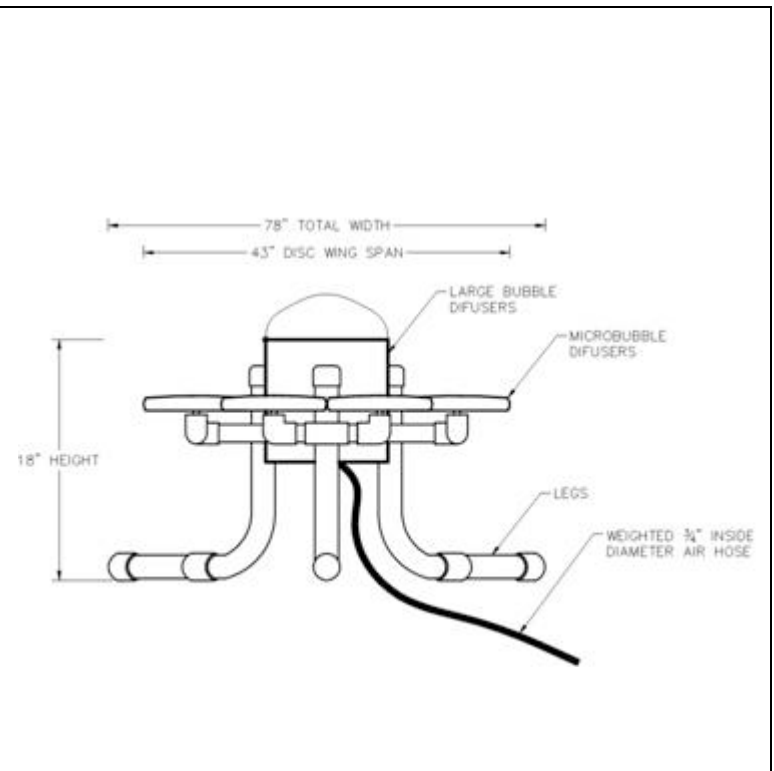

## II. Two MARS System Compressors

### Built for Continuous Pond Aeration

- Super-Duty 1/3 Hp motors provides great aerating power while consuming energy conservatively at only 10 amps—costing about \$54.00 per month<sup>1</sup>
- Twin onboard fans provide cooling air through and around the motor and cylinders
- Inlet filter and capacitor come pre-installed
- All wetted aluminum parts treated for corrosion protection against moisture
- Thermal (overheat) protection for the UL recognized motor

### Low Maintenance Design

- Oil less non-lube piston and cylinder
- Permanently lubricated bearings
- Field service capability

### Durable Construction

- Stainless steel valves
- Lightweight die cast aluminum components
- Thin wall, hard-coated aluminum cylinder for maximum heat transfer
- Balanced for smooth, low vibration operation
- Long-life, high performance piston seal

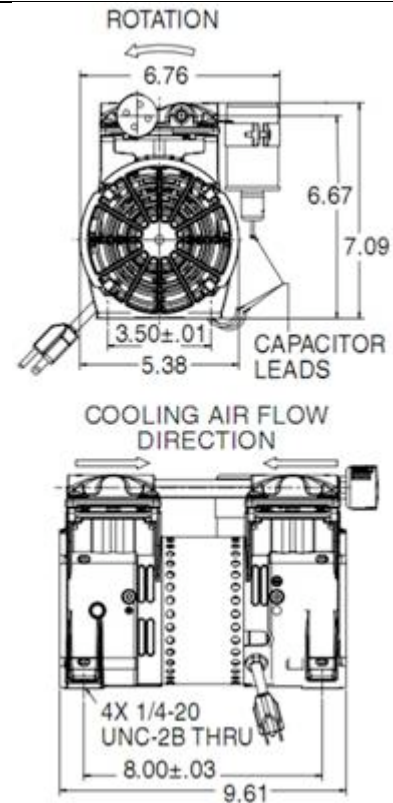

## III. Compressor Enclosure

### Purpose-Built for Aeration

- Roto-Molding integrity maximizes leak protection and is rust free.
- A ventilation fan circulates cooling fresh air through two built in louvers.
- The full size lid both allows full access to the compressors and secures easily for quick operation
- Electric and airline ports are hidden in the bottom of the enclosure, keeping your installation clean and simple.
- Tan coloring blends well into the surrounding environment.

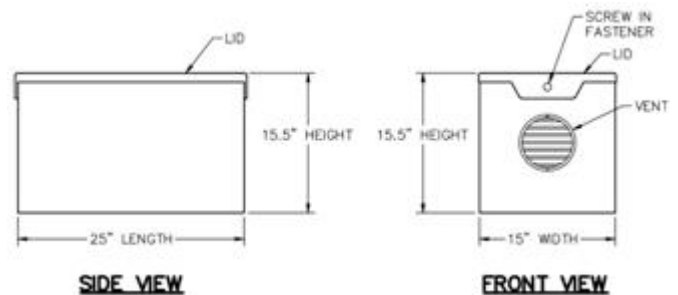

<sup>1</sup> Electricity costs calculated at \$.07 per kWh

## IV. 200' MARS System Flexible Weighted Air Tubing

### Perfect Air Delivery for Every Pond Situation

- Heavy, negative buoyancy construction sinks the airline and keeps it securely in place
- Robust construction resists all punctures, kinks, and ruptures for hassle-free aeration
- Flexible material allows for easy installation
- 5/8" smooth-bore ID allows for low friction air delivery for hundreds of feet
- Black color blends naturally into the pond bottom



## V. 15 lbs Triplepoint Blend Pond Pro-biotic

### Special Triplepoint Blend Pro-biotic

- Synergistic blend of bacteria that work with your MARS Aerator to manage your pond.
- Super concentrated, containing 1.45 trillion colony-forming units per pound.
- Contains extra-voracious strains that consume more nutrients that would otherwise fuel algae, faster.
- Clarifies the water column, leaving crystal clear water.
- Limits the buildup of organic pond muck, reducing the need for dredging.
- Mitigates smelly pond odors
- Effective at temperatures between 45 and 125 degrees.
- Completely safe for humans fish, crustaceans, wildlife, and farm animals when used as directed.
- Non-toxic, non-corrosive. Safe to handle and store.

*Comes in a powder form. Packaging may vary depending on delivery location.*